

2115-211-3250 Block Upconverter, 2750 - 3750 MHz to 20.15 - 21.15 GHz

The 2115-211-3250 Block Upconverter converts **2750 - 3750 MHz (Fc=3250 MHz)** to **20.15 - 21.15 GHz** with a local oscillator at **17.40 GHz**. Front panel LEDs indicate DC Power, External 10 MHz, and PLL Alarm. The gain is +0 dB. Connectors are **SuperSMA** female for the RF out and SMA female for the RF in (designated L-Band) and external reference input and reference output. A three-way switch controls which 10 MHz reference is being used. In the INT position, the internal reference is used, in the EXT position, the external reference is used, and in the AUTO position, the internal reference is used unless a +3 dBm ± 3 dB, 10MHz reference signal is connected to the external reference input. It is powered by a 100-240 ± 10% VAC power supply, and in a 1 3/4" X 19" X 14" rack mount chassis.

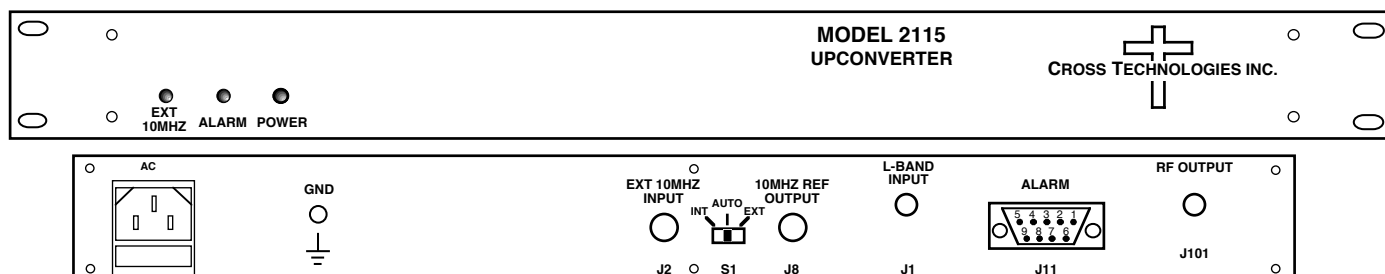

Front and Rear Panels

EQUIPMENT SPECIFICATIONS*

Input Characteristics (designated L-Band)

Impedance/Ret. Loss 50Ω/14 dB
Frequency **2750 to 3750 MHz**
Noise Figure, Max. 20 dB max gain
Input Level range -10 to 0 dBm
Input 1 dB compression **+10 dBm**

Output Characteristics (RF)

Impedance/Ret. Loss 50 Ω /14 dB
Frequency **20.15 to 21.15 GHz**
Output Level Range -10 to 0 dBm
Output 1 dB compr. +10 dBm

Channel Characteristics

Gain +0 ±1 dB at Fc
Image Rejection > 55 dB, min
Spurious, Inband SIGNAL RELATED<-55 dBc in band, **0 dBm out**; SIGNAL INDEPENDENT,<-60 dBm
Spurious, Out of band <-60 dBm, **15.0-20.1 and 21.2-25.0 GHz out**
Intermodulation <-50 dBc for two carriers at Fc ± 2 MHz each at **-5 dBm out**
Frequency Response **±2.0 dB, 20.15 - 21.15 GHz out**; ± 0.5 dB, 40 MHz BW
Frequency Sense Non-inverting

LO Characteristics

LO Frequency **17.40 GHz**
Frequency Accuracy ± 0.01 ppm max over temp int. reference; ext. ref. input

Phase Noise @ F (Hz) >	100	1K	10K	100K	1M
dBc	-60	-70	-80	-90	-110

10 MHz level +3 dBm, ± 3 dB, 75 ohms, External In or Internal out

Controls, Indicators

INT/AUTO/EXT Switch Selects internal or external 10 MHz (rear panel DP3T switch)
Ext 10 MHz Yellow LED, indicates external 10 MHz reference selected
PLL Alarm Red LED, External contact closure
Power Green LED

Other

RF In Connector SMA (female), 50Ω (designated L-band)
RF Out Connector **SuperSMA (female), 50Ω**
10 MHz connectors BNC (female), Works for 50Ω or 75Ω
Alarm Connector DB9 - NO or NC contact closure on Alarm
Size **19 inch standard chassis 1.75" high X 14.0" deep**
Power 100-240 ±10% VAC, 47 - 63 Hz, 25 watts max.

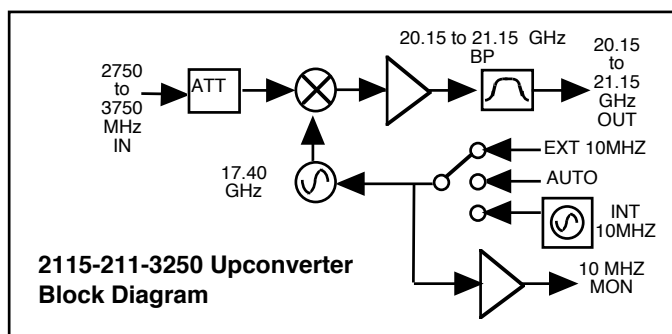

Available Connector Options

267 - 50Ω SuperSMA (RF), 75Ω BNC (L-BAND)
26N - 50Ω SuperSMA (RF), 50Ω N-type (L-BAND)
26S - 50Ω SuperSMA (RF), 50Ω SMA (L-BAND)

*+10 to +40 degrees C; Specifications subject to change without notice